

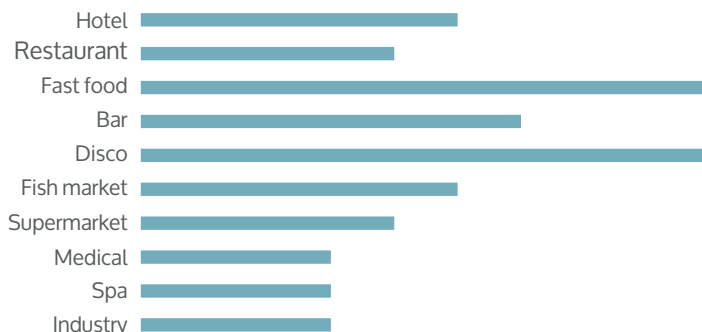

EN 50 NG

Produttore di ghiaccio con contenitore incorporato - Sistema a trafilata - Produzione giornaliera fino a 65 kg
Self-contained ice maker - Pebble system - Daily production up to 65 kg



Caratteristiche Features

- Ghiaccio trafilato, compatto e durevole
Compact and longlasting nuggets
- Struttura esterna AISI 304, Scotch Brite
External structure AISI 304, Scotch Brite
- Evaporatore AISI 304, coclea AISI 303
Evaporator AISI 304 made, auger AISI 303 made
- Bacinella acqua, sistema antipolvere
Dust proof water basin
- Sistema di funzionamento elettromeccanico
Electromechanical functioning
- Condensazione ad aria o ad acqua
Air or water cooling system
- Voltaggio standard e voltaggi speciali
Standard and special voltages
- Pulizia semplificata grazie alle superfici arrotondate
Easy cleaning thanks to rounded surfaces
- RoHS free
RoHS free
- Interruttore On/Off
On/Off switch
- Isolamento contenitore interno privo di HCFC
Internal bin insulation HCFC free

Garanzia 1 Anno / 1 Year Warranty

soggetta a limitazioni / subject to limitations

Produzione 24h / Production 24h

| T. Aria / Air temp. | | T. Acqua / Water temp. | | kg | lbs |
|---------------------|-------|------------------------|-------|----|-----|
| 10°C | 50° F | 7° C | 45° F | 65 | 143 |
| 21° C | 70° F | 15° C | 60° F | 55 | 121 |

Dimensione disponibile Available dimension

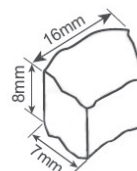

Certificazioni disponibili per questo modello / Certification available for this model





GHIACCIO NUGGET
NUGGET ICE

EN 50 NG

Produttore di ghiaccio con contenitore incorporato - Sistema a trafilata - Produzione giornaliera fino a 65 kg
Self-contained ice maker - Pebble system - Daily production up to 65 kg

Condizioni d'installazione Working conditions

Posizione: **Interna**
Location: **Indoor**

| | Min | Max |
|---|-----------------|------------------|
| T. Ambiente / Ambient temp. | +10° C / +50° F | +43° C / +110° F |
| T. Acqua / Water temp. | +3° C / +37° F | +32° C / +90° F |
| Voltaggio / Voltage | -10% | +10% |
| Pres. acqua ingresso / Water inlet pressure | 1 bar (14 psi) | 6 bar (84 psi) |

Performance / Performances

| | Temperatura acqua / Water temperature | Temperatura acqua / Water temperature | | | | | |
|-------------------------------------|---------------------------------------|---------------------------------------|---------|-------|---------|-------|--------|
| | | 7° C | 45° F | 15° C | 60° F | 21° C | 70° F |
| Temperatura aria Air temperature | 10° C | 65 kg | | | | | |
| | 50° F | | 143 lbs | | | | |
| | 21° C | | | 55 kg | | | |
| | 70° F | | | | 121 lbs | | |
| | 32° C | | | | | 45 kg | |
| | 90° F | | | | | | 99 lbs |

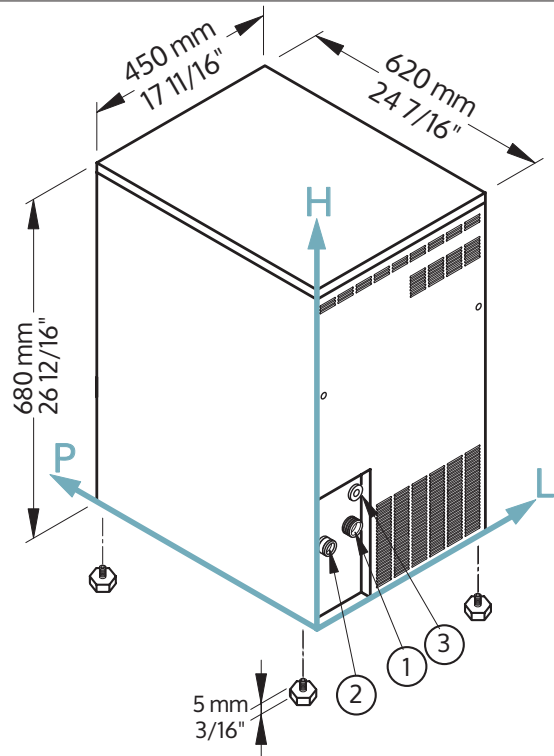

Connessioni / Connections

Le misure sono riferite all'angolo del retro in basso a sinistra (L-H-Ø) / Alle measures are referred to the rear bottom-left corner (L-H-Ø)

- ① Ingresso acqua / Water in: 106 mm / 4 3/16" - 135 mm / 5 5/16" - 3/4"
- ② Scarico acqua / Water out: 55 mm / 2 3/16" - 140 mm / 5 8/16" - 24 mm / 15/16"
- ③ Connessione elettrica / Electrical connection: 114 mm / 4 8/16" - 218 mm / 8 9/16"

Informazioni tecniche / Technical information

| | | | |
|--|--|-------------------------------------|-------------------------------|
| Prod. in 24h / Production 24h | 55 kg / 121 lbs | Consumo d'acqua / Water consumption | A: 1 l/kg - 12 gal/100 lbs |
| Capacità contenitore, fino a / Storage capacity, up to | 10 kg / 22 lbs | | W: 5 l/kg - 59,9 gal/100 lbs |
| Condensazione / Cooling system | A - W | Dimensioni (L-P-H mm) | 450 - 620 - 680 |
| Dimensioni indicative nugget / Approximate nugget size | 8 x 16 x 7 | Sizes (L-P-H in) | 17 11/16 - 24 7/16 - 26 12/16 |
| Refrigerante / Refrigerant | R290 | Dimensioni imballo (L-P-H mm) | 505 - 675 - 850 |
| Voltaggio standard / Standard voltage | 220-240 V ~ 50 Hz | Sizes with pack (L-P-H in) | 19 14/16 - 26 9/16 - 33 7/16 |
| Potenza media assorbita / Average power cons. | 410 W | Peso netto / Net weight | 56 kg / 123 lbs |
| Fusibile / Fuse | 10 A | Peso lordo / Gross weight | 64 kg / 141 lbs |
| Finitura / Finish | AINI 304 Stainless Steel, scotch brite | | |

Tutti i dati tecnici sono da considerarsi validi alle seguenti condizioni:
All the technical information must be considered at the following condition:

Dimensioni esclusi i piedini / Size without feet
Temperatura ambiente +21° C / Ambient temperature +21° C
Temperatura acqua +15° C / Water temperature +15° C
Potenza media assorbita a +43° C (Voltaggio standard) / Average power consumption at +43° C (standard voltage)

I modelli ed i dati riportati possono essere soggetti a modifiche senza alcun preavviso
Models and specifications are subject to change without notice

Rev.00 - Issued March 2020